

CHARTER BUSINESS® INTERNET

INTERACTIVE WELCOME KIT

800.314.7195
Charter-Business.com





CHARTER BUSINESS[®] INTERNET

INTERACTIVE WELCOME KIT

[GETTING
STARTED](#)[SERVICE
INSTALLATION](#)[AFTER
INSTALLATION](#)[VALUE ADDED
SERVICES
OVERVIEW](#)[ONGOING
SERVICE AND
SUPPORT](#)[GLOSSARY](#)[ADDITIONAL
INFO](#)

THANK YOU FOR CHOOSING CHARTER BUSINESS[®] INTERNET

Charter's high-speed network gives your business a competitive edge. Charter's technology and support improve your company's responsiveness and productivity. And that gives you the ability to run your business better. You've already determined the kind of service you require. Now you're ready to log on and get to work.

Please use this interactive kit as a guide to help you make the most of your [Charter Business[®] Internet](#). By clicking through the navigation at the top of this page you'll find easy-to-follow instructions for getting your office ready for installation and using all the services your new internet connection has to offer.

We encourage you to print and store this guide in a convenient location, close to your computer, so that you may reference it in the future.

Should you have any additional questions or concerns regarding your new internet service, our highly trained customer service representatives and technical support personnel can be reached by calling [800.314.7195](tel:800.314.7195). We look forward to meeting all your communications needs with one simple connection for Internet, Phone, and TV.

Thank you for choosing Charter Business.

**Turn your contacts on to affordable,
powerful solutions from Charter
Business and you could earn a
\$50 credit on your bill.**

Click on **ADDITIONAL INFO** tab for more information.



CHARTER BUSINESS[®] INTERNET

INTERACTIVE WELCOME KIT

[GETTING STARTED](#)[SERVICE INSTALLATION](#)[AFTER INSTALLATION](#)[VALUE ADDED SERVICES OVERVIEW](#)[ONGOING SERVICE AND SUPPORT](#)[GLOSSARY](#)[ADDITIONAL INFO](#)

1 GETTING STARTED

1.1 CHARTER BUSINESS SERVICE CHOICES

Charter Business[®] offers a choice of internet access speeds as well as the following included features:

- » Desktop Security*
- » Custom Hosting - Email, Web and Domain**
- » PowerBoost*** (select speeds)

Your service order details the initial service options you have selected. You've already chosen the speed combination that best meets your needs. The next step is to work through the installation process.

Custom Hosting

For customers with custom hosting, Charter provides email accounts and web space on a domain provided.

1.2 COMPUTER SYSTEM MINIMUM REQUIREMENTS

Charter Business Internet access service is compatible with most systems, servers, and local area networks. To ensure your service functions at optimal speed and performance, review your system requirements prior to installation.

The most current system requirements are maintained online.

Go to Charter-Business.com. Click on the link: [Support](#).

*Includes 3 licenses, protecting all computers on the network may require additional licenses.

**Included Web Hosting features Starter web hosting package with 500MB storage, 1 domain name and 2 email accounts. Additional charges for extra email accounts may apply. Annual domain name registration charge may apply.

***Availability of PowerBoost on any single download session is subject to network availability. PowerBoost is a registered trademark of Comcast Corporation.



CHARTER BUSINESS[®] INTERNET

INTERACTIVE WELCOME KIT

GETTING
STARTED

SERVICE
INSTALLATION

AFTER
INSTALLATION

VALUE ADDED
SERVICES
OVERVIEW

ONGOING
SERVICE AND
SUPPORT

GLOSSARY

ADDITIONAL
INFO

1 GETTING STARTED

1.3 CHARTER PRIVACY POLICY AND ACCEPTABLE USE POLICY

Before using Charter's Internet services, familiarize all users with the Charter Privacy Policy and Acceptable Use Policy.

Charter Privacy Policy

The Charter Privacy Policy covers important facts about information Charter collects, how Charter uses and protects it, and the limited circumstances under which Charter may disclose some of that information. You can find the policy at [Charter-Business.com](https://www.charter-business.com), then click on the Privacy Policy link.

Acceptable Use Policy

The Acceptable Use Policy prohibits commercial customers from reselling or redistributing network access and services, except for customers who are explicitly permitted by contract. You can find this policy online at [Charter-Business.com](https://www.charter-business.com), then click on the AUP link. You must accept this policy before you can use your CB Internet service.



CHARTER BUSINESS[®] INTERNET

INTERACTIVE WELCOME KIT

[GETTING STARTED](#)[SERVICE INSTALLATION](#)[AFTER INSTALLATION](#)[VALUE ADDED SERVICES OVERVIEW](#)[ONGOING SERVICE AND SUPPORT](#)[GLOSSARY](#)[ADDITIONAL INFO](#)

2 SERVICE INSTALLATION

2.1 INSTALLATION AND VERIFICATION OF SERVICE

On the day of installation, Charter will provide a coaxial cable network connection to the modem. The installer will verify that the connection is active and demonstrate that internet access is available.

Charter does not install software, modify customer computer configurations or local area networks, or connect the customer equipment to the modem.

2.2 CONNECTION OF EQUIPMENT TO THE CHARTER MODEM

It is your responsibility to make the physical connection between your equipment and the modem as well as to manage the configuration and operation of your computer equipment and any local area network.

Note: Before you connect your equipment to the Charter modem, be sure you have a current backup of your computer data and operating system configuration.

To connect your equipment to the Charter modem, we recommend the following steps:

- » Shut down and unplug your computer from its electrical connection.
- » Unplug the cable modem's electrical connection.
- » Verify that the cable modem is connected to the cable wall outlet. If not:
 - Attach one end of the coaxial cable to the back of the cable modem.
 - Attach the other end to the cable wall outlet.
- » Connect the cable modem to your computer/router/firewall/server via either the Ethernet cable or USB cable.
 - Plug one end of the cable into the appropriate connection on the computer.
 - Plug the other end into the cable modem.
 - Make sure the cable is securely seated in its connector.

CHARTER BUSINESS[®] INTERNET

INTERACTIVE WELCOME KIT

GETTING
STARTED

SERVICE
INSTALLATION

AFTER
INSTALLATION

VALUE ADDED
SERVICES
OVERVIEW

ONGOING
SERVICE AND
SUPPORT

GLOSSARY

ADDITIONAL
INFO

2 SERVICE INSTALLATION

- » Plug the cable modem into its electrical connection and verify that the front-panel lights are on. (Refer to the instructions that accompanied the modem for specific additional information.)
- » Plug your computer into its electrical connection.
- » Restart the computer.

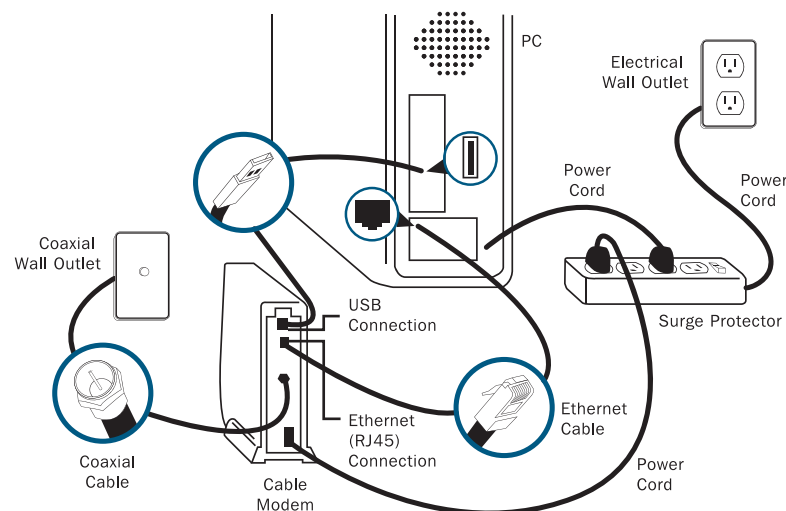

Note: Either USB or Ethernet cable is required, not both. Also, Charter strongly recommends always using a surge protector.

CHARTER BUSINESS[®] INTERNET

INTERACTIVE WELCOME KIT

[GETTING STARTED](#)
[SERVICE INSTALLATION](#)
[AFTER INSTALLATION](#)
[VALUE ADDED SERVICES OVERVIEW](#)
[ONGOING SERVICE AND SUPPORT](#)
[GLOSSARY](#)
[ADDITIONAL INFO](#)

3 AFTER INSTALLATION

SMC8004-BCM



The Modem includes LED indicators on the front panel that simplify installation and network troubleshooting.

LABEL	LED COLOR	ON	FLASHING	OFF
Power	Green	Power is supplied to the Modem	N/A	Power is not supplied to the Modem
Cable	Amber	Successfully tuned to downstream	Attempting to tune to upstream	N/A
Cable	Green	Successfully tuned to downstream and upstream	N/A	N/A
Status	Green	Cable Modem has finished CMTS registration	Attempting to obtain IP and config file	Modem is scanning for downstream and/or upstream
Ethernet	Green	Connected at 10 or 100 Mbps	N/A	Not Ethernet link detected
USB	Green	USB port connected	N/A	No USB link detected



ITEM	DESCRIPTION
CATV	Connect your cable line to this port.
USB	Connect a USB Cable from your PC to this port.
ETH	10/100 Auto-sensing switch port (RJ-45). Connect devices on your local area network to this port (such as a PC, hub, or switch).
Power	Connect the included power adapter to this port.
Reset	Use this button to reset the power or restore the default factory settings.

CHARTER BUSINESS[®] INTERNET

INTERACTIVE WELCOME KIT

[GETTING STARTED](#)
[SERVICE INSTALLATION](#)
[AFTER INSTALLATION](#)
[VALUE ADDED SERVICES OVERVIEW](#)
[ONGOING SERVICE AND SUPPORT](#)
[GLOSSARY](#)
[ADDITIONAL INFO](#)

3 AFTER INSTALLATION

SMC8014 (WIRED OR WIRELESS)



The Gateway includes LED indicators on the front panel that simplify installation and network troubleshooting.

LABEL	LED COLOR	ON	FLASHING	OFF
Power	Green	Power is supplied to the Gateway	N/A	Power is not supplied to the Gateway
Diag	Amber	System Failure. Reboot Gateway	N/A	Normal Operation
Cable	Green	Successfully connected to cable network	Attempting to connect to network	N/A
Traffic	Green	Cable Modem has finished CMTS registration	Attempting to register with CMTS	N/A
WLAN	Green	Good Wireless Link	Data transmitting	No Wireless Link
LAN (1-4)	Green	Connected at 10 or 100 Mbps	Data transmitting	No Ethernet link detected
USB	Green	USB port connected	Data transmitting	No USB link detected



ITEM	DESCRIPTION
Power	Connect the included power adapter to this port.
Reset	Use this button to reset the power or restore the default factory settings.
LAN 1-4	Four 10/100 Auto-sensing switch ports (RJ-45). Connect devices on your local area network to these ports (such as a PC, hub, or switch).
USB	Connect a USB Cable from your PC to this port.
CATV	Connect your cable line to this port.

CHARTER BUSINESS[®] INTERNET

INTERACTIVE WELCOME KIT

[GETTING STARTED](#)
[SERVICE INSTALLATION](#)
[AFTER INSTALLATION](#)
[VALUE ADDED SERVICES OVERVIEW](#)
[ONGOING SERVICE AND SUPPORT](#)
[GLOSSARY](#)
[ADDITIONAL INFO](#)

3 AFTER INSTALLATION

SMCD3G



LABEL	LED COLOR	ON	FLASHING	OFF
Power	Green	Power is supplied to the Gateway	N/A	Power is not supplied to the Gateway
DS	Green	Synchronized on 1 channel only	Scanning for DS channel	N/A
DS	Blue	Synchronized with more than 1 channel (DS Bond mode)	N/A	N/A
DS and US	Green	N/A	Operator is performing maintenance	N/A
US	Green	Ranging is complete on 1 channel only	Ranging is in progress	Scanning for DS channel
US	Blue	Ranging is complete, operate with more than 1 channel (US Bond mode)	N/A	N/A
ONLINE	Green	Gateway is operational	Cable interface is acquiring IP, ToD, CM configuration	Gateway is offline
LINK	Green	Gateway is operational	Data is transmitting	No Ethernet link detected
DIAG	Amber	System failure	N/A	Normal operation
LAN 1 - 4	Green	Connected at 10 or 100 Mbps	Data is transmitting	No Ethernet link detected
LAN 1 - 4	Blue	Connected at 1 Gbps	Data is transmitting	No Ethernet link detected
USB	Green	Reserved for future use	N/A	N/A



ITEM	DESCRIPTION
POWER (12VDC)	Connect the supplied power adapter to this port.
LAN 1-4	Four 10/100/1000 auto-sensing RJ-45 switch ports. Connect devices on your local area network such as a computer, hub, or switch to these ports.
USB	USB 2.0 high-speed port for storing configurations externally.
CABLE	Connect your coaxial cable line to this port.
RESET BUTTON	Use this button to reset the power or restore the default factory settings (see "Restoring Factory Defaults," below). This button is recessed to prevent accidental resets of your Gateway.

CHARTER BUSINESS[®] INTERNET

INTERACTIVE WELCOME KIT

[GETTING STARTED](#)
[SERVICE INSTALLATION](#)
[AFTER INSTALLATION](#)
[VALUE ADDED SERVICES OVERVIEW](#)
[ONGOING SERVICE AND SUPPORT](#)
[GLOSSARY](#)
[ADDITIONAL INFO](#)

3 AFTER INSTALLATION

UBEE DDC2700

Installation problems with the wireless cable modem are commonly due to the cable network and its topography. LEDs on the front panel of the wireless cable modem reveal operational status and help you determine problem areas.



LEDs on the Front of the Modem.

LABEL	DESCRIPTION
pwr	Indicates that the wireless cable modem has successfully completed internal power-on tests.
usb	Indicates connectivity between the USB port on the wireless cable modem and a PC's USB port.
sync	Indicates the connection status between the wireless cable modem and the cable network. The LED is lit when the wireless cable modem has established a downstream channel with the cable service provider's Cable Modem Termination System (CMTS).
ready	Indicates that the wireless cable modem has completed the ranging/registration process and is ready to send/receive data.
wlan	Indicates that the wireless interface is enabled. The LED will flash when passing wireless traffic.
Enet 1, 2, 3, 4	Indicates connectivity between the Ethernet port on the wireless cable modem and the Ethernet port on a PC or Mac. This LED blinks when the wireless cable modem is transferring or receiving data over the Ethernet cable.

Connectors on the Back of the Modem

(This list of connectors describes where to connect the cables and power adapter when installing the wireless cable modem.)

CONNECTOR	DESCRIPTION
PWR	This is where you plug the included power adapter. Remember to use only the power adapter that came with the wireless cable modem.
Ethernet	10/100 Port 1, 2, 3, 4: This is where you plug the Ethernet cable. The other end connects to the Ethernet port on the PC or NIC
USB Port	This is where you plug the included USB cable. The other end connects to the USB port on your PC.
Cable Connector	This is where you connect the coaxial cable (not included) that leads to the cable splitter (not included) or the cable wall outlet.



CHARTER BUSINESS[®] INTERNET

INTERACTIVE WELCOME KIT

[GETTING STARTED](#)[SERVICE INSTALLATION](#)[AFTER INSTALLATION](#)[VALUE ADDED SERVICES OVERVIEW](#)[ONGOING SERVICE AND SUPPORT](#)[GLOSSARY](#)[ADDITIONAL INFO](#)

3 AFTER INSTALLATION

Assistance

If you need assistance, visit our Customer Support page at Charter-Business.com or call Charter Business Customer Care (open 24 hours a day, 7 days a week) at 800-314-7195.

When calling, please have the following information ready, so we can help you as quickly as possible:

- » The exact and full customer name on the Commercial Service Agreement.
- » Your Charter Business customer account number.
- » The name of the designated contact person for your company (if it is not you) and his or her contact information (phone, address, email).
- » For customers with a static IP address, the static IP addressing information provided during installation.

A Charter Business representative will help you with your internet access connection and make sure that the modem is working correctly. Charter will not be able to assist you with computer or local-area network problems.

Note: If you are operating a local-area network, you may be instructed to connect one computer directly to the modem in order to determine the problem's source. This involves connecting the Ethernet or USB cable directly from one computer to the Ethernet or USB port on the modem. In this situation, you must disconnect any other equipment (e.g., router or hub) that may be connected to the modem.



CHARTER BUSINESS[®] INTERNET

INTERACTIVE WELCOME KIT

GETTING
STARTEDSERVICE
INSTALLATIONAFTER
INSTALLATIONVALUE ADDED
SERVICES
OVERVIEWONGOING
SERVICE AND
SUPPORT

GLOSSARY

ADDITIONAL
INFO

4 VALUE ADDED SERVICES OVERVIEW

A feature-rich, easy-to-use service that offers the comprehensive tools you need to set up and manage your email accounts, establish a web presence, and register a business-specific domain.

4.1 CUSTOM HOSTING

Email services

Choose the number of email accounts that suit your business needs[†] based on the industry standard Microsoft Exchange platform.

- » Choose the domain name format that suits your business needs: <username>@ <your-domain>
- » Add and delete mailboxes as you need them
- » Access emails from any internet-enabled computer using our webmail access
- » Block mail from designated unwanted senders and allow mail to be delivered from specific senders
- » Reduce junk mail using our anti-spam programs
- » Protect your email from malicious viruses that may be attached to messages

Website Hosting

A variety of customized solutions are available depending on your storage requirement, transfer bandwidth, sitebuilder sites, FTP accounts, or MySQL databases.^{††}

- » Choose the domain name format that suits your business needs <username>@<your-domain>
- » Control panel that lets you manage your web development environment
- » Generous disk storage and transfer limits
- » An easy-to-understand site builder application that helps you create a web site even if don't have any experience with web development
- » Web development tools that let you customize the look and functionality of your web site

Domain Name Service (DNS) Hosting

Register your custom domain name or transfer an existing domain and assign it to your website and email service so that your business can effectively reach customers and establish brand credibility through a consistent presence.^{†††}

[†]Additional charges for extra email accounts may apply.

^{††}Included Web Hosting features Starter web hosting package with 500 MB storage, 1 domain name and 2 email accounts.

^{†††}Annual domain name registration charge may apply.



CHARTER BUSINESS[®] INTERNET

INTERACTIVE WELCOME KIT

GETTING
STARTEDSERVICE
INSTALLATIONAFTER
INSTALLATIONVALUE ADDED
SERVICES
OVERVIEWONGOING
SERVICE AND
SUPPORT

GLOSSARY

ADDITIONAL
INFO

4 VALUE ADDED SERVICES OVERVIEW

4.2 DESKTOP SECURITY†

Charter Business Desktop Security is a highly-affordable, highly-advanced suite designed to help guard small business PCs and laptops from many cyber threats. Easy to manage and easy to maintain, this fully-automated system provides:

- » Virus and Spyware Protection — Provides real-time protection against many viruses, worms and Trojans, stopping attacks via e-mail, web, floppy disks and CD-ROMs. Also detects and removes spyware and rootkits secretly installed on PCs.
- » Rapid Response to New Threats — Updates virus definitions several times daily to help guard against new viruses.
- » Internet Shield — Helps prevent intrusion from hackers and other internet-based threats. Advanced components including firewall and application control ensure your security while online.
- » Spam Control — Controls all inbound mail and separates spam by placing it in a separate folder.
- » Web-Based Management Portal — Provides 24/7 security overview for real-time monitoring and troubleshooting of all protected workstations.
- » OS Flexibility — Supports popular operating systems including Windows 2007, Windows XP[®] - Home, Professional, and Media Center editions (Service Pack 2 or newer), and Windows Vista[®] (32-bit).

4.3 MANAGED SECURITY

Charter Business Managed Security provides network and data protection for businesses of any size. The system can also reduce threats and increase efficiency by allowing you to control what content is accessible to employees online. And with the addition of Charter Business Managed Security VPN, your protection can be extended to multiple offices and off-site workers.

Charter Business Managed Security provides firewall, intrusion detection, antivirus, content filtering, anti-spam, and IPSec VPN capabilities.

†Includes three licenses, protecting all computers on the network may require additional licenses. Charter Business does not guarantee the security of data or guarantee this service will protect against all threats.



CHARTER BUSINESS[®] INTERNET

INTERACTIVE WELCOME KIT

[GETTING STARTED](#)[SERVICE INSTALLATION](#)[AFTER INSTALLATION](#)[VALUE ADDED SERVICES OVERVIEW](#)[ONGOING SERVICE AND SUPPORT](#)[GLOSSARY](#)[ADDITIONAL INFO](#)

4.4 MANAGED INTERNET ROUTER

Managed Internet Router service takes the hassles out of your network with:

- » Enhanced service level via a single point of contact for help with internet network connection issues, 24/7 customer support, and technical assistance
- » Improved reliability through proactive internet network monitoring that reduces downtime and technical issues
- » A lower total cost of network ownership by outsourcing the management and operational control of your network connection and equipment to Charter Business

Wireless Connectivity for your Business

The Wireless Managed Internet Router solution provides a wireless connection for your business. It features an easy set up interface for users to access the internet or shared resources. Create a wireless presence for visitors, or extend coverage throughout your building, office park, or entire community. Plus, you still get all the benefits of Managed Internet Router including 24x7 monitoring, management, customer care and network support.

4.5 BACKUP

Charter Business can automatically protect your old data so you can focus on creating new data. Our system is easy, secure, and scalable to handle the needs of virtually any size business. We encrypt your data while it is being transferred and while it is in storage to help you meet your business's privacy and security regulations.

With storage tiers of 2, 5, 10, 20, 40, 60, 80, 100GB - and more custom options - you can select the capacity you need now and scale up quickly and easily when your needs increase. Our service saves you money by leveraging your existing broadband capacity during off hours and by allowing you to back up data to an off-site location without having to pay for additional media delivery. Plus, choose from these retention options: 3 days, 7 days, or 30 days.



CHARTER BUSINESS[®] INTERNET

INTERACTIVE WELCOME KIT

[GETTING STARTED](#)[SERVICE INSTALLATION](#)[AFTER INSTALLATION](#)[VALUE ADDED SERVICES OVERVIEW](#)[ONGOING SERVICE AND SUPPORT](#)[GLOSSARY](#)[ADDITIONAL INFO](#)

5 ONGOING SERVICE AND SUPPORT

5.1 QUESTIONS

For additional information about email, web, DNS, domain names and transferring or redirecting DNS services, see the Charter Business online FAQ section at <http://www.Charter-Business.com>; click on the links, [Customer Support](#)>[Browse for Solutions](#).

5.2 PAYMENT OPTIONS

Charter Business will accommodate monthly bill payments by check, credit card, or electronic fund transfers. To make arrangements for automatic payment, call the Charter Business Customer Care Center at 800.314.7195. Of course, you can always pay in person at the nearest Charter payment office.

Note: Billing begins on the day of installation.

5.3 CHANGING OR UPGRADING SERVICES

To fulfill the Charter Business commitment to your success, we keep our services updated and at the leading edge of communication technologies. For your reference, current service packages, speeds, and service options can be viewed online at [Charter-Business.com](http://www.Charter-Business.com).

Contact your Charter Business representative or the Business Customer Care Center to:

- » Purchase additional custom email and web storage, and additional IP addresses.
- » Increase your download / upload speed.



CHARTER BUSINESS[®] INTERNET

INTERACTIVE WELCOME KIT

GETTING
STARTED

SERVICE
INSTALLATION

AFTER
INSTALLATION

VALUE ADDED
SERVICES
OVERVIEW

ONGOING
SERVICE AND
SUPPORT

GLOSSARY

ADDITIONAL
INFO

6 GLOSSARY

At Charter Business, we provide you with the best services available. Our account executives, service representatives and, support staff are committed to providing you with knowledge-based solutions for your business needs. Don't hesitate to contact us whenever you have questions or need assistance. The following glossary of terms has been provided to enable better communication.

Coaxial Cable

A type of wire that consists of a center wire surrounded by insulation and then a grounded shield of braided wire. The shield minimizes electrical and radio frequency interference.

DNS

Domain name system (or service or server) is an internet service that translates domain names into numeric IP addresses. It is a worldwide network of servers that maintains a distributed, shared database, mapping the name and corresponding IP address of every publicly accessible device on the internet.

DOCSIS

DOCSIS, or data over cable service interface specification, defines interface standards for cable modems and supporting equipment.

Domain Name

A domain is the text name corresponding to the numeric IP address of a computer on the internet. For example, in the URL <http://www.Charter-Business.com/ProductsAndServices.aspx>, the domain name is Charter-Business.com. Every domain name has a suffix that indicates which top-level domain (TLD) it belongs to, such as .gov, .edu, .org, and .com. Because the internet is based on IP addresses, rather than on domain names, every web server requires a domain name system (DNS) server to translate domain names into IP addresses.

Dynamic IP

An IP address that changes. See IP and Static IP / Dynamic IP.

Email Server

Often referred to as "mail server," an email server is a computer within your network that works as your virtual post office. A mail server usually includes a database of user accounts that the mail server recognizes and handles within the network.

FTP

File transfer protocol is a protocol for exchanging files over the internet. FTP works in the same way as HTTP for transferring web pages from a server to a browser, and SMTP for transferring email. Like these technologies, FTP uses the internet's TCP/IP protocols to enable data transfer.

Host

A computer that is connected to a TCP/IP network, including the internet. Each host has a unique IP address.

HTTP

Hypertext transfer protocol. The communication protocol that defines how web documents are requested and delivered over the internet.



CHARTER BUSINESS[®] INTERNET

INTERACTIVE WELCOME KIT

[GETTING STARTED](#)[SERVICE INSTALLATION](#)[AFTER INSTALLATION](#)[VALUE ADDED SERVICES OVERVIEW](#)[ONGOING SERVICE AND SUPPORT](#)[GLOSSARY](#)[ADDITIONAL INFO](#)

6 GLOSSARY

ICANN

Internet corporation for assigned names and numbers.

IP

Internet protocol (IP) specifies the format of packets (a piece of a message containing a destination address) and the addressing scheme. Most networks combine IP with TCP (transmission control protocol), which establishes a virtual connection between a destination and a source. IP by itself is something like the postal system. It allows you to address a package and drop it in the system, but there's no direct link between you and the recipient. TCP/IP, on the other hand, establishes a connection between two hosts so that they can send messages back and forth for a period of time.

IP Address

An identifying number for a computer or device on an IP network; messages are delivered to the destination's IP address. Connecting a private network to the internet requires using registered IP addresses (called internet addresses) to avoid duplicates.

Static/Dynamic IP

Static IP addresses do not change; dynamic addresses do change (although the domain name stays the same). With a dynamic IP address, the need for change is determined by the system's DHCP (dynamic host configuration protocol) server configuration; it is often beneficial to large network administrators. Static IP addresses are most advantageous for customers who use certain types of VPN software or who are running a server on-site.

ISP

An internet service provider is a company that provides access to the internet. The ISP provides the software and information you need so that, equipped with a modem, you can log on to the internet, browse the World Wide Web and USENET (a worldwide bulletin board system), and send and receive email.

Internet

A global network connecting millions of computers in more than 100 countries. The internet is decentralized, and each internet computer, called a host, is independent. The internet is not synonymous with World Wide Web.

LAN/WAN

A computer network. Local area networks are confined to a single building or group of buildings. However, one LAN can be connected to other LANs over any distance. A system of LANs connected in this way is called a wide area network (WAN).

Modem

A modulator-demodulator (modem) is a device that enables a computer to transmit data over telephone or cable lines. Computer information is stored digitally, but transmitted information is transmitted in the form of analog waves. A modem converts information between the two forms.



CHARTER BUSINESS[®] INTERNET

INTERACTIVE WELCOME KIT

[GETTING STARTED](#)[SERVICE INSTALLATION](#)[AFTER INSTALLATION](#)[VALUE ADDED SERVICES OVERVIEW](#)[ONGOING SERVICE AND SUPPORT](#)[GLOSSARY](#)[ADDITIONAL INFO](#)

6 GLOSSARY

Registering a Domain Name

The only way to register and start using a domain name is to use the services of a domain name registrar. The domain name industry is regulated and overseen by ICANN, the organization that is responsible for certifying companies as domain name registrars. Only a domain name registrar is permitted to access and modify the master database of domain names maintained by InterNIC.

Router

A device that forwards data packets along networks (e.g., between a LAN and its ISP's network). Routers are located where two or more networks connect.

Server

A computer or device on a network that manages network resources.

SMTP

Simple mail transfer protocol. The internet standard protocol for transferring electronic mail messages from one computer to another. SMTP specifies how two mail systems interact and the format of control messages they exchange to transfer mail.

TCP/IP

Transmission control protocol. See IP.

URL

Uniform resource locator, the global address of documents and resources on the World Wide Web. The first part of the address (such as http:// or ftp://), indicates what protocol to use. The second part (Charter-Business.com) specifies the IP address or the domain name.

VPN

Virtual private network, a private data network that makes use of the public telecommunication infrastructure, maintaining privacy through the use of a tunneling protocol and security procedures. The goal of a VPN is to provide the same capabilities of a private network at a much lower cost by using the shared public infrastructure.

World Wide Web

A system of internet servers that supports specially formatted documents.



CHARTER BUSINESS[®] INTERNET

INTERACTIVE WELCOME KIT

GETTING
STARTED

SERVICE
INSTALLATION

AFTER
INSTALLATION

VALUE ADDED
SERVICES
OVERVIEW

ONGOING
SERVICE AND
SUPPORT

GLOSSARY

ADDITIONAL
INFO



Charter Business[®] Refer-A-Business program

WHAT IT IS

The Charter Business[®] Refer-A-Business Program makes it easy to earn a \$50 credit on your Charter Business bill by letting us know about business contacts who could benefit from our services.

HOW IT WORKS

Simply refer another business to us by completing a lead form on the Charter Business website:

Charter-Business.com/BusinessReferral. We'll contact your referral and handle the rest. Once your referral's Internet or TV services are installed and they are billed, we'll give each of you a \$50 credit toward your bills. (Your referral may also subscribe to phone, however, credit will not be applied to phone-only accounts.*)

WHO TO REFER

Any clients, vendors, or other contacts who might like a great deal on reliable Internet, Phone, and TV solutions and who aren't already Charter Business customers.

THE CHARTER BUSINESS BUNDLE[®]

Referrals can save time and money with one bill and get discounts off our standard rates when they bundle Charter Business Internet, Phone, and/or TV

Visit Charter-Business.com/BusinessReferral

©2011 Charter Communications. Restrictions may apply. To be eligible for the Charter Business credit, you must be a current Charter Business customer in good standing at the time of installation and billing activation of the new customer's account. Credits will only be paid on installed sales and will be paid as soon as administratively possible after the account has been verified. Serviceability by Charter Business for a business is not guaranteed. The credit is paid one time and has no cash value. Offer valid for 120 days up to and including contract sign date. Charter Business will confirm timely service installation before credit is issued. See program rules for credit process and eligibility policy at Charter-Business.com/BusinessReferral. *Credit will not be applied to new or current customers subscribing only to Charter Business Phone service. Credit will be applied to video and/or internet account as applicable. CB.016.intCD.0111